



## Industrial Weighing Systems

9 Richmond St. Picton, ON Canada K0K 2T0

Ph: 613-786-0016 Cell: 613-921-0397 Fax: 613-476-5293

E-mail [info@iwsystems.ca](mailto:info@iwsystems.ca) Website: [www.iwsystems.ca](http://www.iwsystems.ca)

This document shows calibration instructions extracted from Manuals we have on file that may not necessarily match your current model.

For your reference only.

IWSystems provides repair services to instruments and load cells

On site calibrations

For additional information please contact us.

# CALIBRATION & SET-UP PROCEDURES



Indicators are factory calibrated during inspection, but must be re-calibrated for use with each customer's specific applications. Before proceeding with calibration, your scale must meet the minimum dead load requirements of this instrument (.75 mV input with zero weight on the scale). If it does not, refer to the Dead Load Compensation Section of this manual.

1. With **POWER OFF** and right panel (as viewed from indicator front) removed as outlined in DISASSEMBLY PROCEDURES; refer to Figure 1 and place switch in the calibration position (Detail C), then **POWER UP** the indicator. **NOTE: On earlier models without switch, J2 is operate position and J3 is calibrate position.**

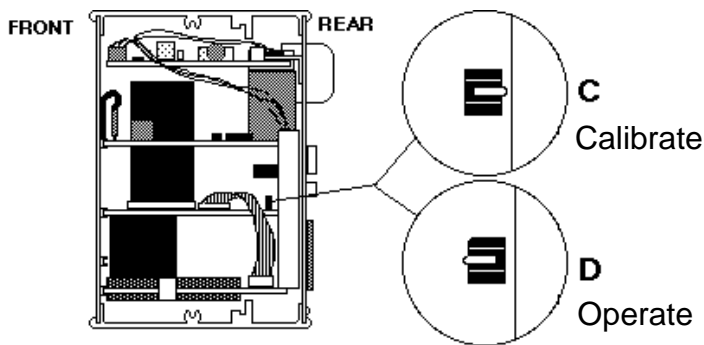
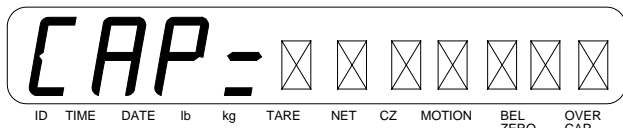

Figure 1 - Right-end view of Indicator showing detail of calibration switch positions.

**NOTE: On each of the following displays, press the ENTER key alone if the displayed value is acceptable.**

2. Indicator will go through a brief display test sequence then display: **CAP=** Capacity



- A. **XXXXXX** blanks if instrument has never been calibrated or **XXXXXX** will display current scale capacity. (Capacity Max. 950,000)
- B. Key in up to 6 digit scale capacity value then press **ENTER** key.

3. Display shows: **din=**, Division Value

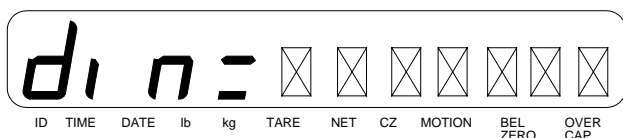

- A. **XXXXXX** are blanks if instrument has never been calibrated or **XXXXXX** will display current scale division value.

- B. Allowable division values are 1 through 9 with trailing (3 Max.) zeros and decimal point in any desired position. EX: .001, .2, 1, 7, 20, etc.
- C. Key in up to 6 digit division value then press **ENTER** key.

4. Display shows: **unitS=** Weight Units

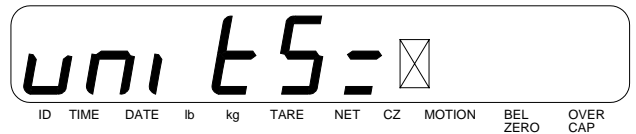

- A. **X** = 1, 2, 3, 4, or 5.  
**1** = LB ONLY  
**2** = KG ONLY  
**3** = LB/KG (Power up in LB. Is switchable to KG via **LB/KG** key.)  
**4** = KG/LB (Power up in KG. Is switchable to LB via **LB/KG** key).\*  
**5** = TONS ONLY. (Apply keypad overlay).
- B. Key in desired unit and press **ENTER** key.

\*NOTE: If the weight units are to be kg, switchable to lb units using the Front Panel switch, then the calibration (CAPACITY, DIVISION, etc.) **must** be done in lb units. The DIVISION value entered **must** be exactly twice the kg division value. The CAPACITY and LOADS entered should be the lb equivalent of the kg values, rounded to the nearest lb DIVISION value. For example, a scale with a CAPACITY of 70,000 kg x 10 kg should be entered as 154320 x 20 lb. If the load used for calibration is 50,000 kg, then the "LoAd" asked for in STEP 6 should be 110240 lb. After Calibration and Set-up procedure is completed, any errors in the displayed weight can be corrected using the Fine Span Adjustment of STEP 20. Note, however, that the indicator **must** be displaying lb. Fine Span Adjustment may be done, correcting the weight error in lb. Leave the Fine Span mode, then check the display in kg mode. To convert weight in pounds to kilograms, multiply pounds by .4536. To convert weight in kilograms to pounds, divide kilograms by .4536

5. Display shows: **C=**, Calibration No.

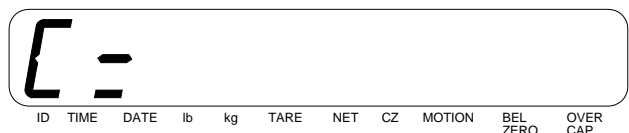

- A. To calibrate without test weights, enter the **C** (calibration) number from the previous calibration (See Step 17). This number should be recorded onto a label attached to the indicator. Press **ENTER** key and proceed to Step 7.

# CALIBRATION & SET-UP PROCEDURES, Cont.

- B. To calibrate using test weights, or to bypass Calibration altogether, press **ENTER** key and proceed to Step 6.

## 6. Display shows: LoAd



- A. Place known accurate weight on scale, key-in the equivalent weight up to 6 digits and press the **ENTER** key; or press **ENTER** key alone to bypass calibration and proceed to Step 8.

## 7. Display shows: unLoAd



**Note: If the display shows HELP A, see Appendix A, Dead Load Compensation Section.**

- A. Remove weight, then press **ENTER** key.

## 8. Display shows: A-r=, Auto-Zero Range

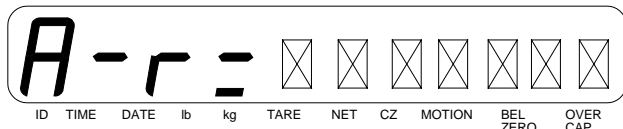

- A. Key-in Auto-Zero Range in number of divisions
- Bench, counter, livestock .....0.6
  - Axle, vehicle, railway .....3.0
  - All other scales .....1.0
  - Non-Commercial .....User Specify
- B. Then press **ENTER** key.

## 9. Display shows: m-r=, Motion Range

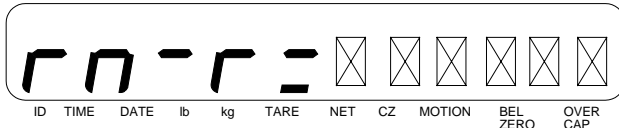

- A. Key-in desired Motion Range in number of divisions:
- Axle, vehicle, railway, livestock .....3.0
  - All other scales .....1.0
  - Non-Commercial .....User Specify
- B. Then press **ENTER** key.

## 10. Display shows SrAtE=, Sample Rate



- A. Key-in Sample Rate from 0.5 to 10 samples per second, then press **ENTER** key.
- Recommended Fill Control .....10
  - Recommended Static Weighing .....2

## 11. Display shows: S1=, Setting 1

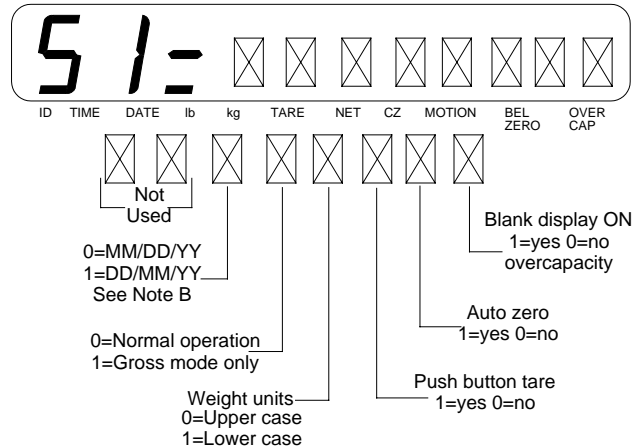

\*Tare is not active if GROSS MODE ONLY. See Note C

- A. Key-in desired settings, then press **ENTER** key.
- B. Date can display or print in standard (MM/DD/YY) or European (DD/MM/YY) Format.
- C. Tare mode is disabled so that the 738 operates only in gross mode.

## 12. Display shows: S2=, Setting 2 (Printer Port)

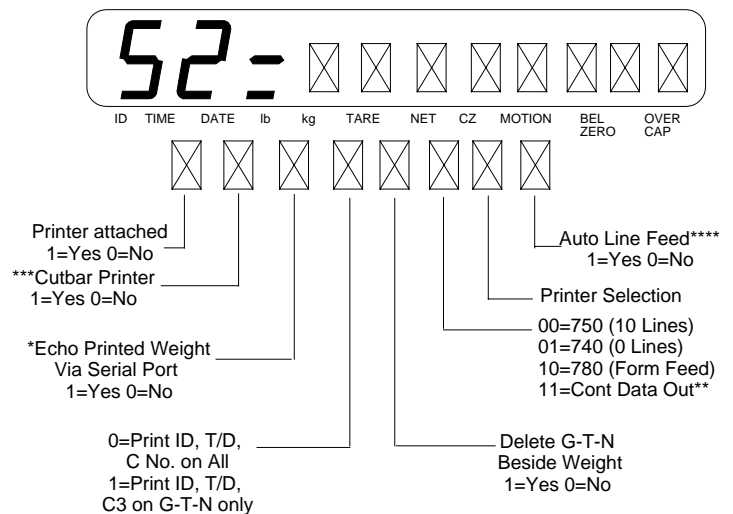

- A. Key-in desired setting, then press **ENTER** key.

\*If setting is 1, the weight transmitted to the device attached to the serial port is the last weight printed on the device attached to the printer port (does not apply to continuous data output).

# CALIBRATION & SET-UP PROCEDURES, Cont.

\*\*If continuous data output is selected, time/date, ID, Consec. No. keys DO NOT APPLY. In addition, the cutbar and auto line feed settings are ignored.

\*\*\*If this option is enabled, a 07 HEX character will be sent to the printer to perform the paper cut operation. A 750 type printer should be selected to insure that the paper has been advanced enough so that the printed data is not lost.

\*\*\*\*This option, when enabled, will automatically append a line feed after every carriage return in the printer data stream.

## 13. Display shows: **S3=**, Setting 3 (Serial Port No. 1)

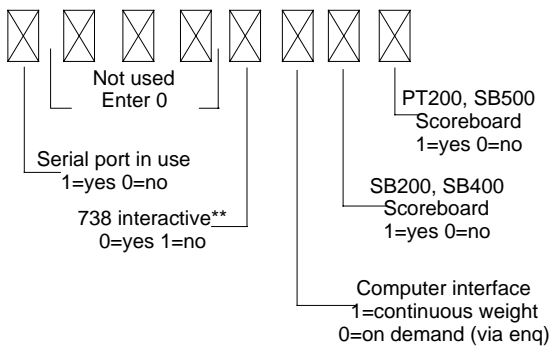
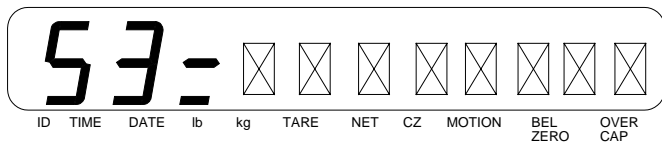

\*\*If 0 - signal device may operate the indicator via serial data and may use the indicator display. Keyboard data will also be transmitted. If 1 - no interaction is allowed (except for ENQ on COMPUTER INTERFACE/ON DEMAND applications).

- A. Key-in desired settings, then press the **ENTER** key.

## 14. Display shows: **b rAtE=**, Baud Rate

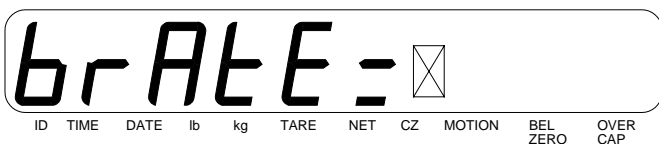

- A. At this prompt, enter the baud rate selection for the printer and serial port. Select the desired baud rate as shown in the following table:

- X = 1 - 4800
- 2 - 2400
- 3 - **1200** (Standard Setting)
- 4 - 600
- 5 - 300
- 6 - 9600
- 7 - 19200

- B. After desired baud rate is set, press the **ENTER** key.

## 15. Display shows: **FiLtEr=**, Filter

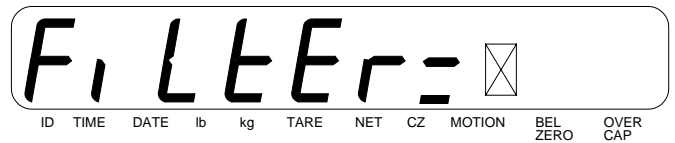

X= 1 to 99\*

- A. Key-in desired setting, then press the **ENTER** key.

\*The number 1 to 99 represents the number of consecutive weigh samples during which the weight deviation cannot exceed the motion range setting. Filter should be set to 1 for all applications except those with high motion characteristics (such as a livestock scale). For livestock scale the following settings are recommended: MOTION RANGE=2, SAMPLE RATE=2, FILTER=4.



**PRINTER USE:** If a printer is connected to the indicator, the following series of TAB displays are for setting the Line Printed On (LL) and the Position On The Line (PP) for Time, Date, ID, Consecutive Transaction Number, and Gross, Tare, Net labeling of weight. Refer to Figure 2 below showing relative (LL) and (PP) dimensions for various printers; to Table A showing available printed Characters per inch for various printers; and to information in the appropriate Operator's manuals for various printers being used.

# CALIBRATION & SET-UP PROCEDURES, Cont.

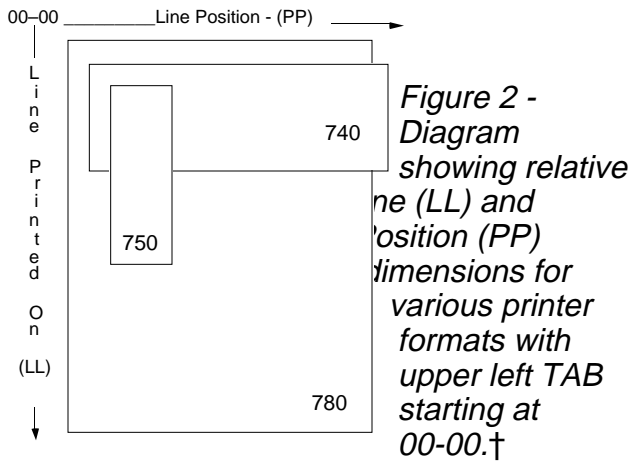

†The position on the line has a maximum value that will vary according to the print format and character size selected.

	740/750 (max.tab)*
Char/inch	40
12.4	
780	8-1/2" x11"
Char/inch	(max. tab)*
10	80
12.4	90
17	99

**TABLE A**

\*Maximum TAB settings indicate the extreme right hand margin reached by the printer.

16. If printer is connected - Display shows: **tAbS t = (Time)**

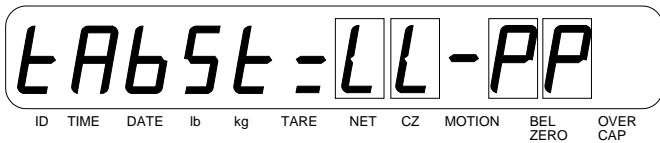

- A. Set LL then press **ENTER** key.
- B. Set PP then press **ENTER** key.

Display then shows: **tAbS d = (Date)**

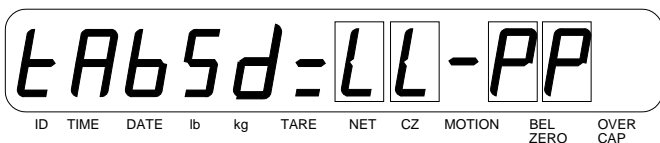

- A. Set LL then press **ENTER** key.
- B. Set PP then press **ENTER** key.

Display then shows: **tAbS id = (ID)**

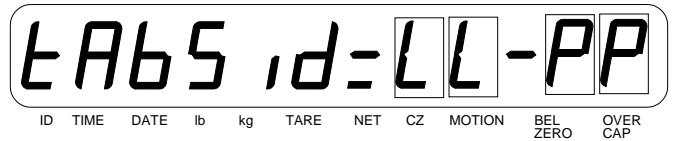

- A. Set LL then press **ENTER** key.
- B. Set PP then press **ENTER** key.

Display then shows: **tAbS Cn = (Consecutive transaction number)**

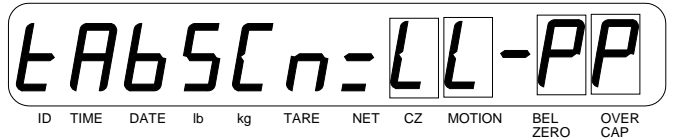

- A. Set LL then press **ENTER** key.
- B. Set PP then press **ENTER** key.

Display then shows: **tAbS G = (Gross)**

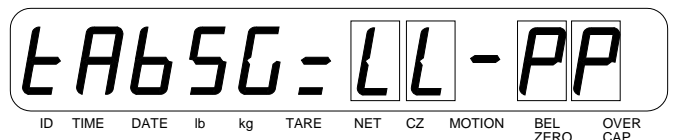

- A. Set LL then press **ENTER** key.
- B. Set PP then press **ENTER** key.

Display then shows: **tAbS tA = (Tare)**



- A. Set LL then press **ENTER** key.
- B. Set PP then press **ENTER** key.

Display then shows: **tAbS n = (Net)**

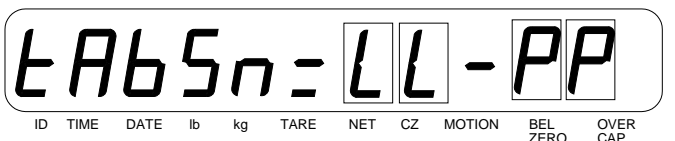

- A. Set LL then press **ENTER** key.
- B. Set PP then press **ENTER** key.

# CALIBRATION & SET-UP PROCEDURES, Cont.



Additional TABS may be requested at this point if a special option is installed that produces additional print fields.

**NOTE:** If a 780 type printer has been selected, this prompt will be displayed after all the tab settings have been entered. Enter the length of the form in lines.



Example: For a form size of 5.5 inches to be printed at 6 lines per inch, enter 33 (6 lines/inch\* 5.5 inches).

Display then shows: **Print ?**



A. Press **ENTER** key. Printer will run test print showing data locations.

Display then shows: **AGAn ?**



- A. Enter **0** for **NO**-display goes to Step 17.
- B. Enter **1** for **YES**-display goes back to beginning of Step 16.



Additional setup information may be requested at this point if the **PWC/FILL CONTROL OPTION, TRUCK STORAGE MEMORY BOARD OPTION, or other special options** are installed.

17. Display shows: **C=XXXXXXXX**

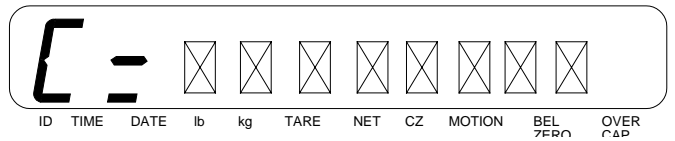

A. **XXXXXXXX** = Calibration number to be saved and used for indicator calibration outlined in Step 5.

**NOTE:** **XXXXXXXX** may be in any sequence or combination containing 8 of the following 16 characters:

**0-9** =Numbers 0 through 9

**G** =Gross    **n** =Net    **d** =Date

**t** =Tare    **P** =Print    **.** =(decimal)

B. After recording **C** number, press **ENTER** key.

18. Display will then show: **done**

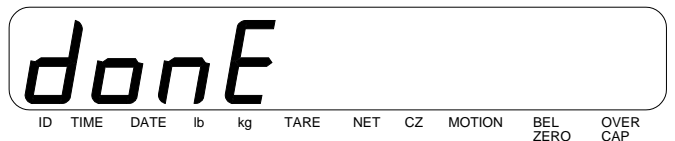

19. With power **ON**, refer to Figure 1 in Step 1, place the switch in the operate position, **POWER DOWN**, then **POWER UP** indicator. Check calibration with a known weight. If OK, reassemble indicator. The Indicator is ready for use. If not OK, proceed to Step 20.

20. **FINE SPAN ADJUSTMENT**- After calibration and set-up procedure is complete and a known weight is on the scale, any small error displayed plus or minus the known weight may be corrected as follows:

## CALIBRATION & SET-UP PROCEDURES, Cont.

- A. With indicator POWER ON and displaying weight, place the switch in the calibrate position (See Step 1). An upper case **C** will appear in the right most position of the display. This disables all keys except **0**, **1**, and **ZERO**.
- B. Press **1** to increase displayed weight 1 grad per press; press **0** to decrease displayed weight 1 grad per press. Press **ZERO** to zero scale.
- C. After making the correction to the displayed weight, remove the test weight from the scale deck. If zero has shifted and one or more divisions are displayed, zero the scale by pressing the **ZERO** key. Place the test weight back on the scale. If the displayed weight is still incorrect by one or more divisions, press the **1** or **0** key to change the displayed weight until it is correct.
- D. Perform the previous operation (Step C) until the span adjustment is correct and the scale returns to a solid zero when the test weight is removed.
- E. When the span adjustment is complete, place the switch in the operate position and reassemble indicator. Display will show new **C** number (Step 17). Record new **C** number.
- F. Press **ENTER** key.
- G. Indicator is ready for use.

**21. SETUP AND CALIBRATION REVIEW-**The setup and calibration review allows you to inspect the setup and calibration parameters without changing the switch inside the indicator. To invoke this feature:

- A. Hold down the \* key and turn ON the indicator simultaneously; when the introduction message appears, release the \* key. After the introduction, the indicator will be in the review mode. It will go through the same sequence as setup and calibration; however, the only valid key is **ENTER**. To look at the next parameter, press the **ENTER** key.
- B. After the review is complete, the message DONE will be displayed. Turn the indicator OFF, then back ON.