

**MAGPOWR**®

A Maxcess  
International  
Company

**TSU**

**UNDER PILLOW BLOCK LOAD CELLS FOR  
LIVE SHAFT ROLLS**

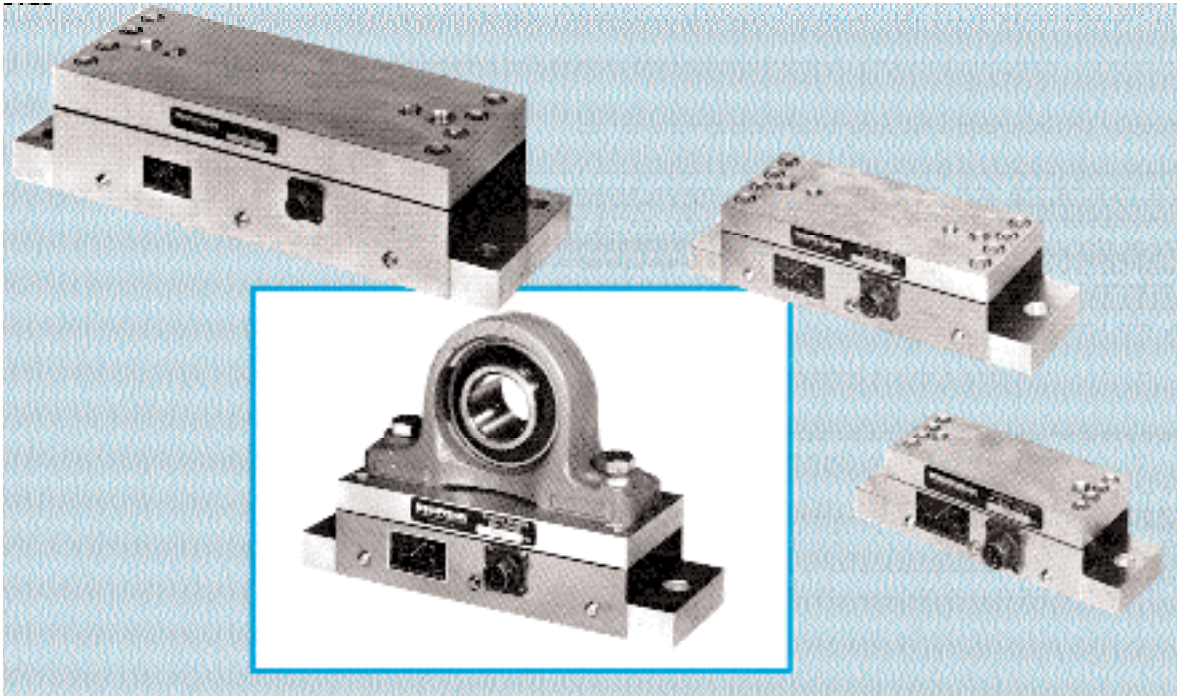

CE

#### FEATURES / BENEFITS

Positive overload stops in both compression and tension modes of operation

Rugged industrial construction

Four foil strain gauges in a full Wheatstone bridge - same as expensive instrumentation load cells

Corrosion resistant finish on all external parts

Simple installation

Sensing actual web tension

Pre-drilled and tapped mounting holes for pillow block bearings - no additional adapters required

MAGPOWR model TSU Load Cells enable you to read and control web tension in your machine by simply bolting the model TSU load cell under your present roll support bearings. Once installed, they accurately measure the tension forces on the machine sensing roll created by the web, and can display and control the web tension through MAGPOWR tension readouts and controls.

The model TSU Load Cell is ruggedly constructed with built-in mechanical overload stops in both force directions, and will stand up to mill duty. A full Wheatstone bridge arrangement is incorporated in each load cell for the most accurate means of measuring web tension.

Application of the TSU Load Cells is normally in pairs, one under each pillow block bearing which supports the sensing roll. When installed in this manner, the two load cells accurately measure the total force on the entire roll created by tension in the web, and precisely display in on a MAGPOWR tension readout, regardless of web position.

MAGPOWR model TSU Load Cells are available in three sizes and seven load ratings with sensing capabilities of 0 to 5,000 pounds. All sizes are already drilled and tapped to accept standard pillow block bearings. No additional adapter plates for mounting the pillow block bearings are required.

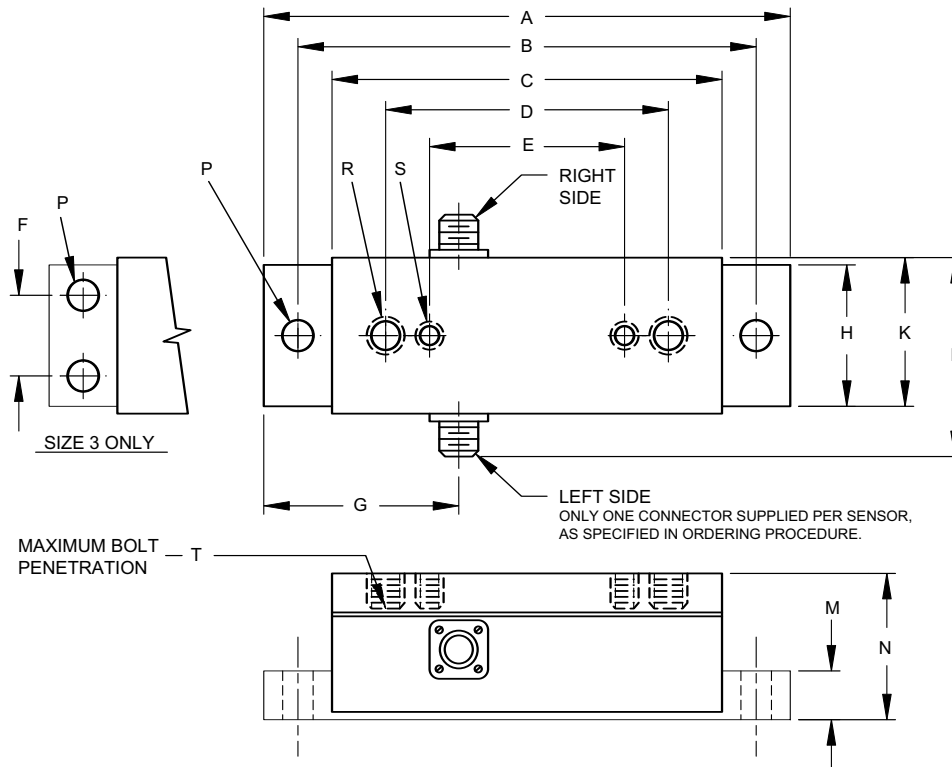

### DIMENSIONS INCH MODEL DIMENSIONS (INCHES)

MODEL	A	B	C	D	E	F	G	H	K	L	M	N	P	R	S	T
1	6.75	5.875	5	3.625	-	-	2.75	1.812	2	2.53	.625	1.87	.406	3/8-16	-	.625
2	9	8	7	5.125	3.625	-	3.75	2.812	3	3.53	.750	2.12	.531	1/2-13	3/8-16	.625
3	13.5	12.25	11	8.375	6.875	2.750	6.25	4.312	4.5	5.03	1	3.18	.531	3/4-10	5/8-11	1

### METRIC MODEL DIMENSIONS (MILLIMETERS)

MODEL	A	B	C	D	E	F	G	H	K	L	M	N	P	R	S	T
1	171	149.2	127	92.1	-	-	70	46	51	64	16	47	10.3	3/8"-16	-	16
2	229	203.2	178	130.2	92.1	-	95	71	76	90	19	54	13.5	1/2"-13	3/8"-16	16
3	343	311.2	279	212.7	174.6	69.8	159	110	114	128	25	81	13.5	3/4"-10	5/8"-11	25

### SIZE LOAD RATINGS AVAILABLE, lb (kg)

1	25 (11.3), 50 (22.7), 150 (68.0)
2	150 (68.0), 500 (227), 1000 (454)
3	1000 (454), 2500 (1,134), 5000 (2,268)

### SPECIFICATIONS

Gage Resistance	350 ohm
Excitation Voltage	10 vdc nominal
Output Signal	21 mvdc nominal per load cell at full load rating
Operating Temperature	-30° to 95° C
Temperature Effect on Zero	.02% of rating per °C
Combined Non-linearity and Hysteresis	.5% of full scale maximum
Repeatability	.2% of full scale maximum
Overload Stops	Internal at 105% to 150% of full load rating
Deflection at Full Load	.009 in (23 mm)
Weight	TSU-1, 4 1/4 lb; TSU-2, 10 1/2 lb; TSU-3, 36 lb
Connector	KPT02E-10-6P
MAGPOWR Mating Cable	Part No. SC-15, or mating connector 12A36-1 (pin A, + power; pin B, + signal; pin C, - signal; pin D, - power)

### ORDERING INFORMATION

Model TSU Load Cells are used in pairs - one on each side of the web. When ordering you must specify one left hand unit and one right hand unit for each sensing roll. Order by model number as shown in the following example.

Example: A requirement for a 1,000 lb. capacity load cell of size 2, as shown in the dimension sheet would be specified as TSU2-1000-L for the left side of the sensing roll and as TSU2-1000-R for the right side of the sensing roll.

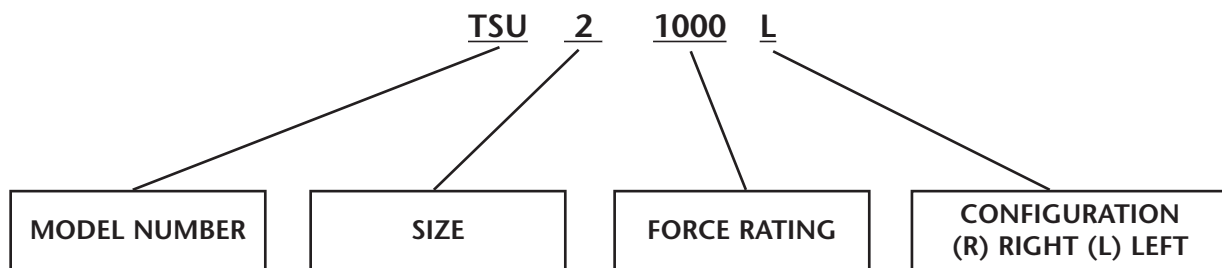

# TSU SIZING

To properly size any TSU model load cell select the case (which resembles your application) from the examples shown below. Using your known maximum tension, roll weight and angles as shown, apply the equation to calculate a "load rating" L. Select a load cell with a load rating greater than that calculated.

Example:

In case 2 below, T=150 lb, X=180°, Y=30°, w=50 lb

then

$$L = 2T \sin(X/2)(\cos Y + \sin Y) + w/2$$

$$L = 2(150)\sin 90^\circ (\cos 30^\circ + \sin 30^\circ) + 25$$

$$L = 2(150)(1)(.866 + .500) + 25$$

$$L = 435 \text{ lb}$$

Select a TSU2-500 Load Cell

SINE/COSINE FUNCTIONS					
Degrees	Sine	Cosine	Degrees	Sine	Cosine
0	.0000	1.000	50	.7660	.6428
5	.0872	.9962	55	.8192	.5736
10	.1736	.9848	60	.8660	.5000
15	.2588	.9659	65	.9063	.4226
20	.3420	.9397	70	.9397	.3420
25	.4226	.9063	75	.9659	.2588
30	.5000	.8660	80	.9849	.1736
35	.5736	.8192	85	.9962	.0872
40	.6428	.7660	90	1.000	.0000
45	.7071	.7071			

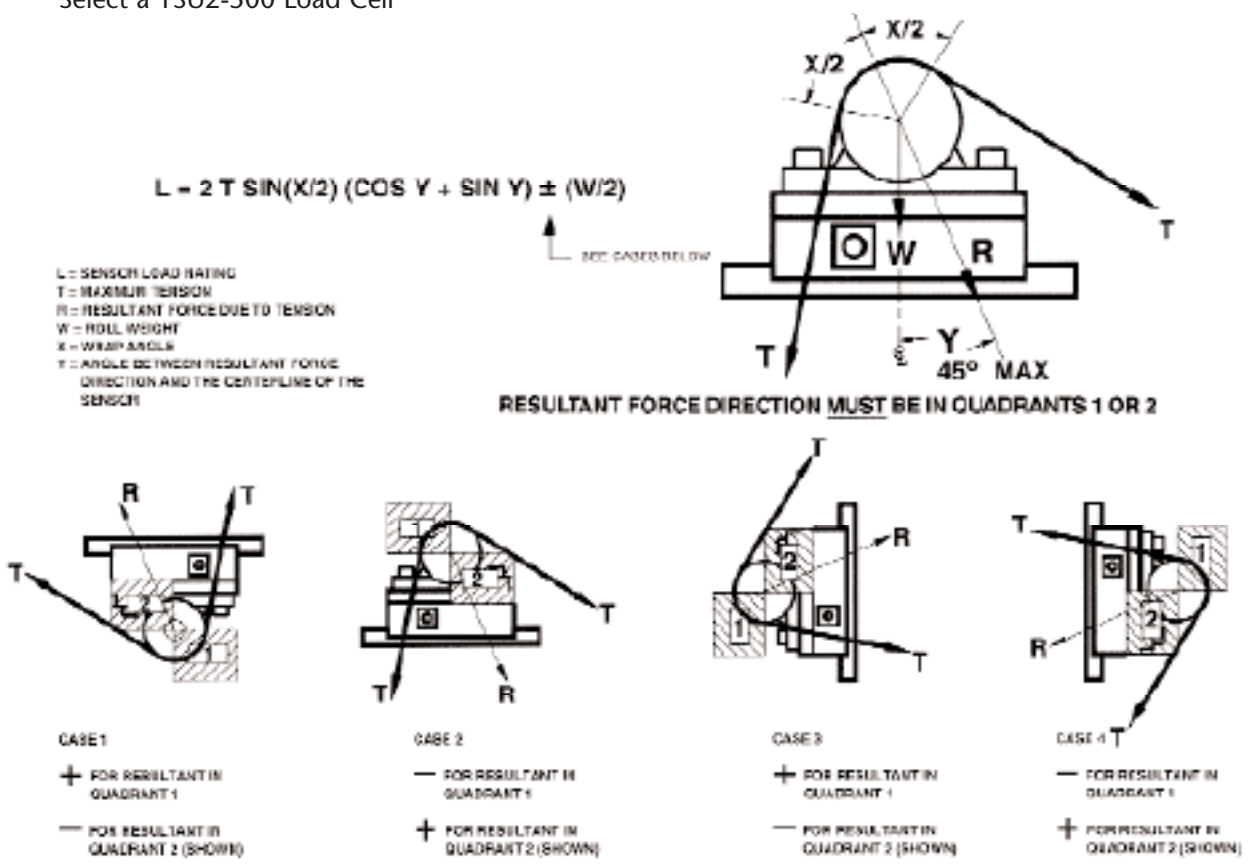

**NOTES:**

Angle Y cannot exceed 45 degrees.

The second term (roll weight "W") of the equation must not exceed 50% of the selected sensor load rating. If it does exceed 50%, select the next larger load rating sensor.

When the resultant force (R) is pulling in a direction away from the sensor, the signal loads must be reversed at the terminal block of the control.



MAGPOWR North America

222 West Memorial Road, Oklahoma City, OK 73114, USA

Phone: 405-755-1600, Fax: 405-755-8425, E-mail: magpowr@magpowr.com, Web: www.magpowr.com